

HF300 3.7KW~37KW 变频器&逆变器风机拆装维护指导书

- 一、 确认变频器断电，并放电 10 分钟以上。变频器上端尽量留出大于 200mm 的空间距离，方便螺丝刀拆装风扇。

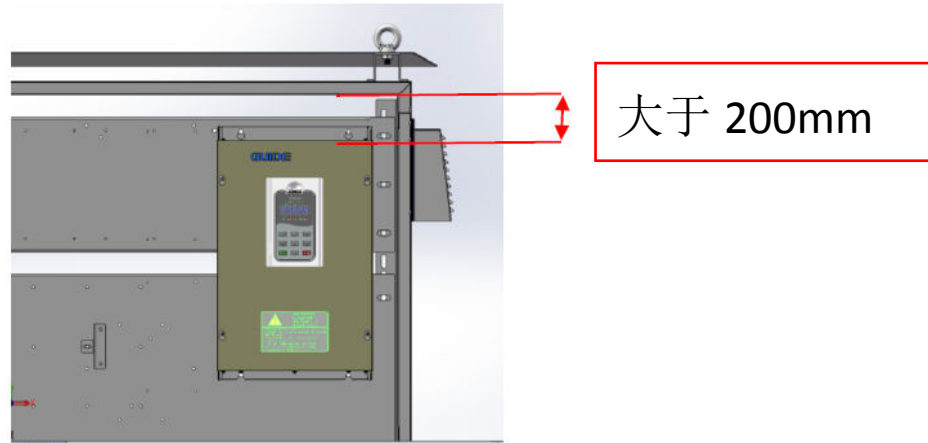

- 二、 拔下风扇对接插头，变频器风扇处于变频器上部。拆卸需要按压对接插头后才能松动卡子拔出。

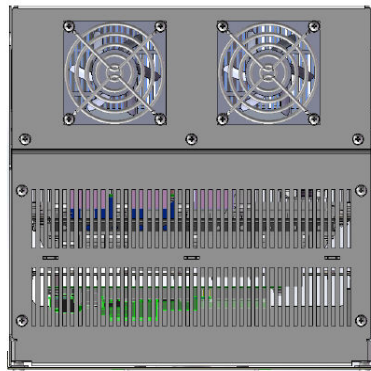

风扇对接插头



三、 分别拆卸螺丝。

变频器上部结构

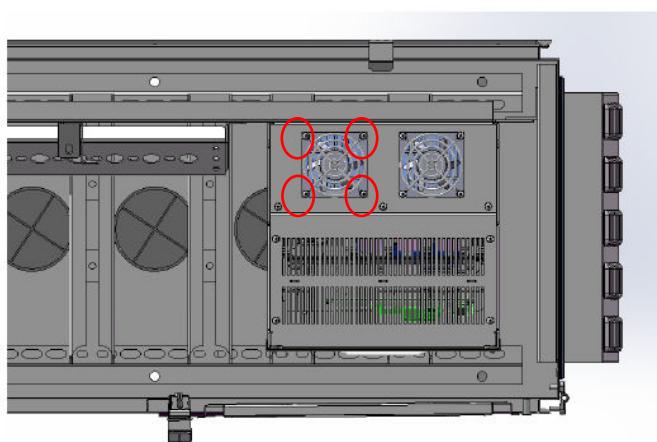

风扇紧固螺丝
向上抽出

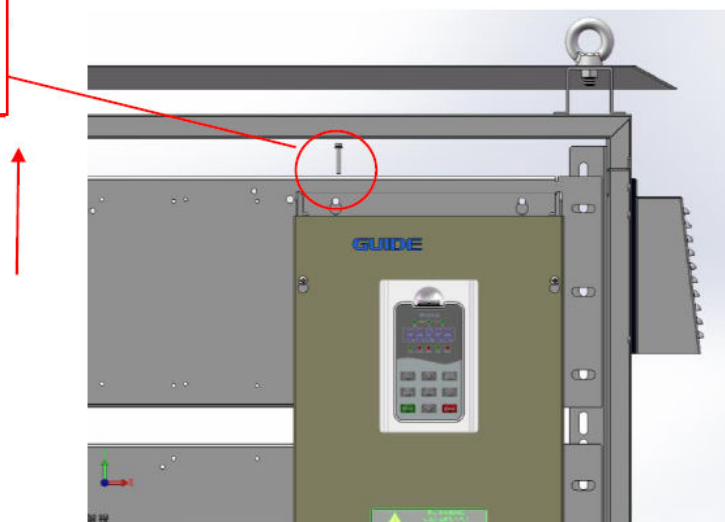

四、 拆卸完螺丝后拿出风扇。

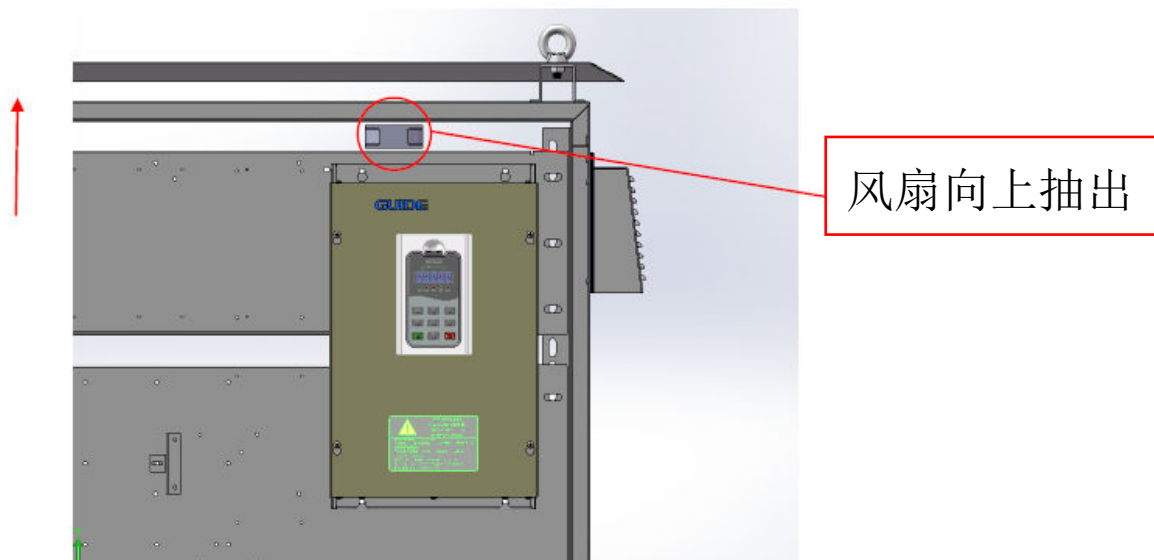

HF300 45KW~160KW 变频器&逆变器风机拆装维护指导书

- 一、 确认变频器断电，并放电 10 分钟以上。变频器下端尽量留出大于 200mm 的空间距离，方便螺丝刀拆装风扇。

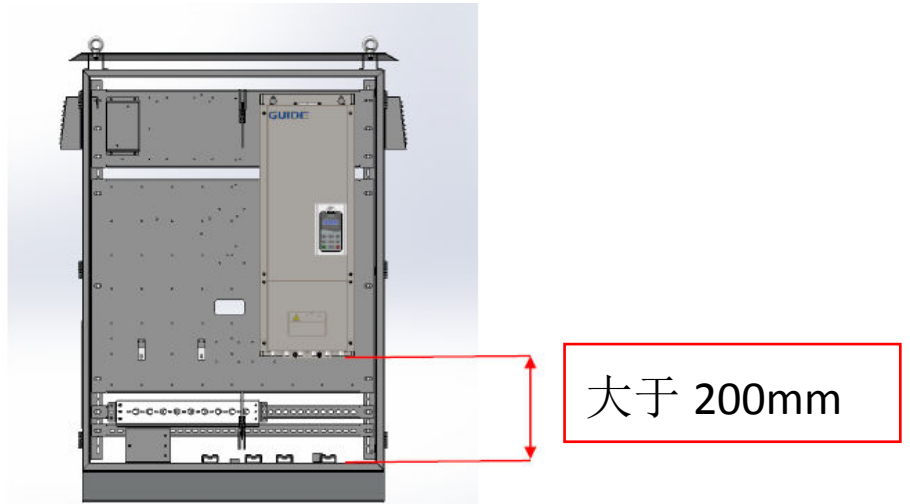

- 二、 拔下风扇对接插头，变频器风扇处于变频器下部。图中实物中对接插头与本机型对接插头为同一款，拆卸需要按压对接插头后才能松动卡子拔出。

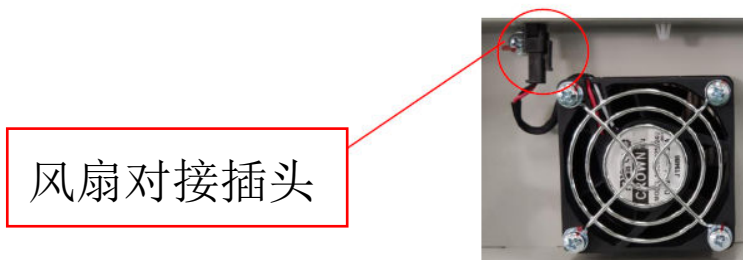
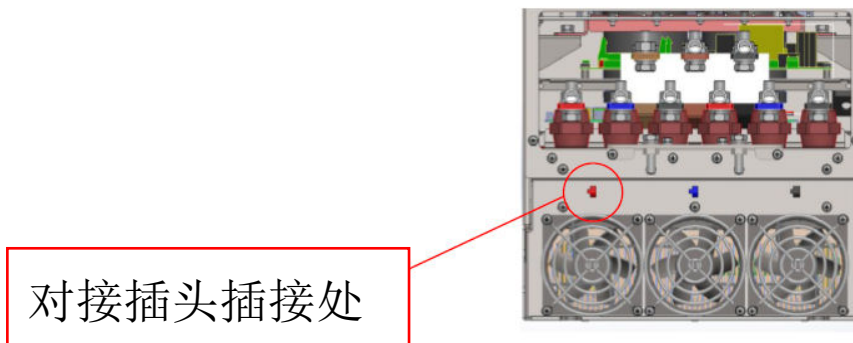

三、 分别拆卸螺丝。

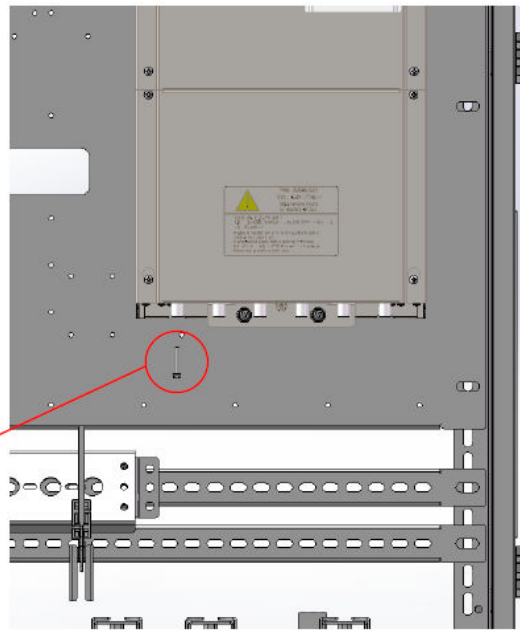
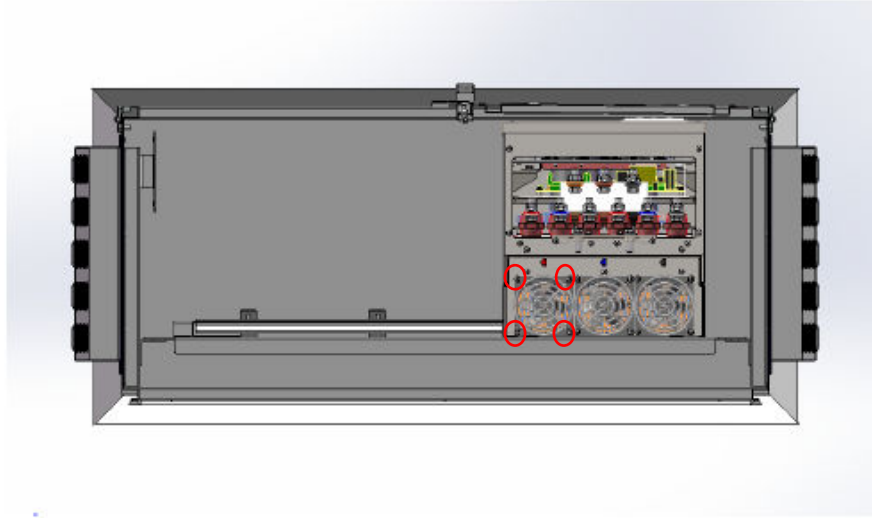

风扇紧固螺丝
向下抽出

四、 拆卸完螺丝后拿出风扇。

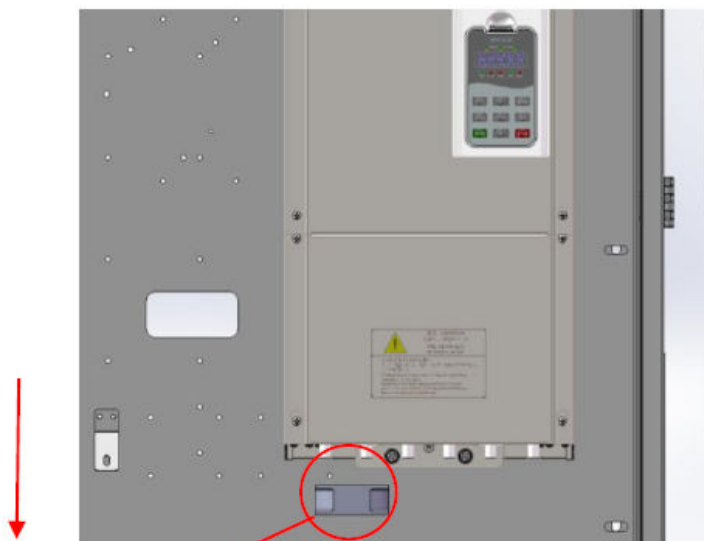

风扇向下抽出

HF300 185~315KW 变频器&逆变器风机拆装指导书

一、把风机电源线拆除

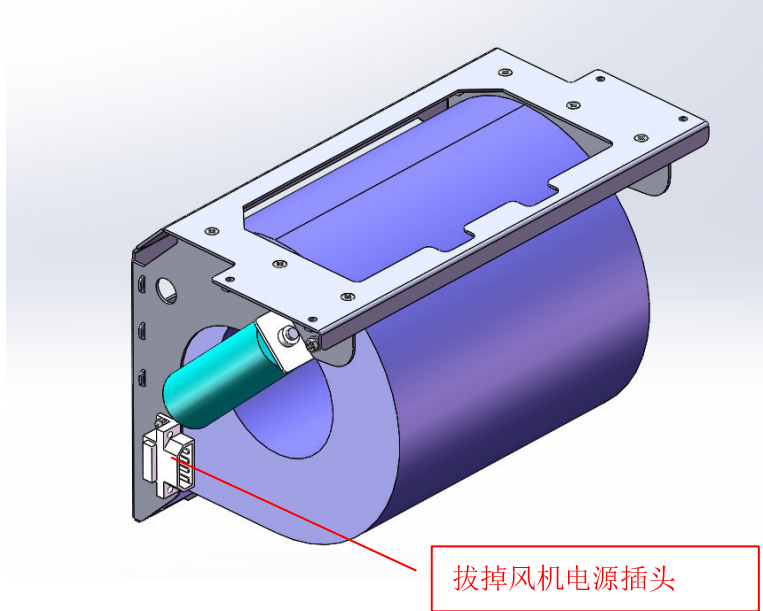

二、拆掉下面盖

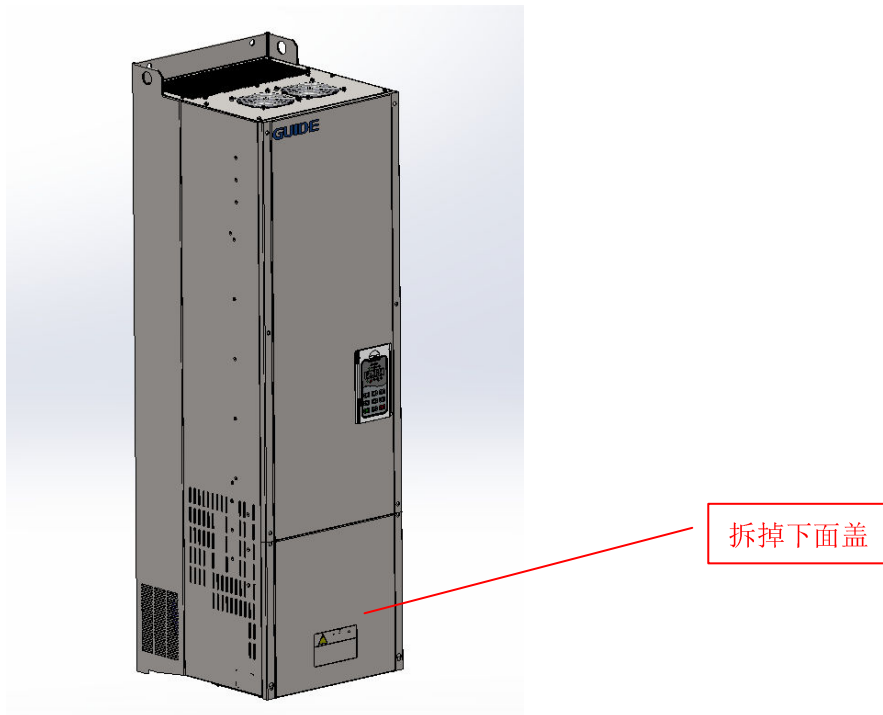

三、拆掉风机组件安装的 4 个 M6 螺栓

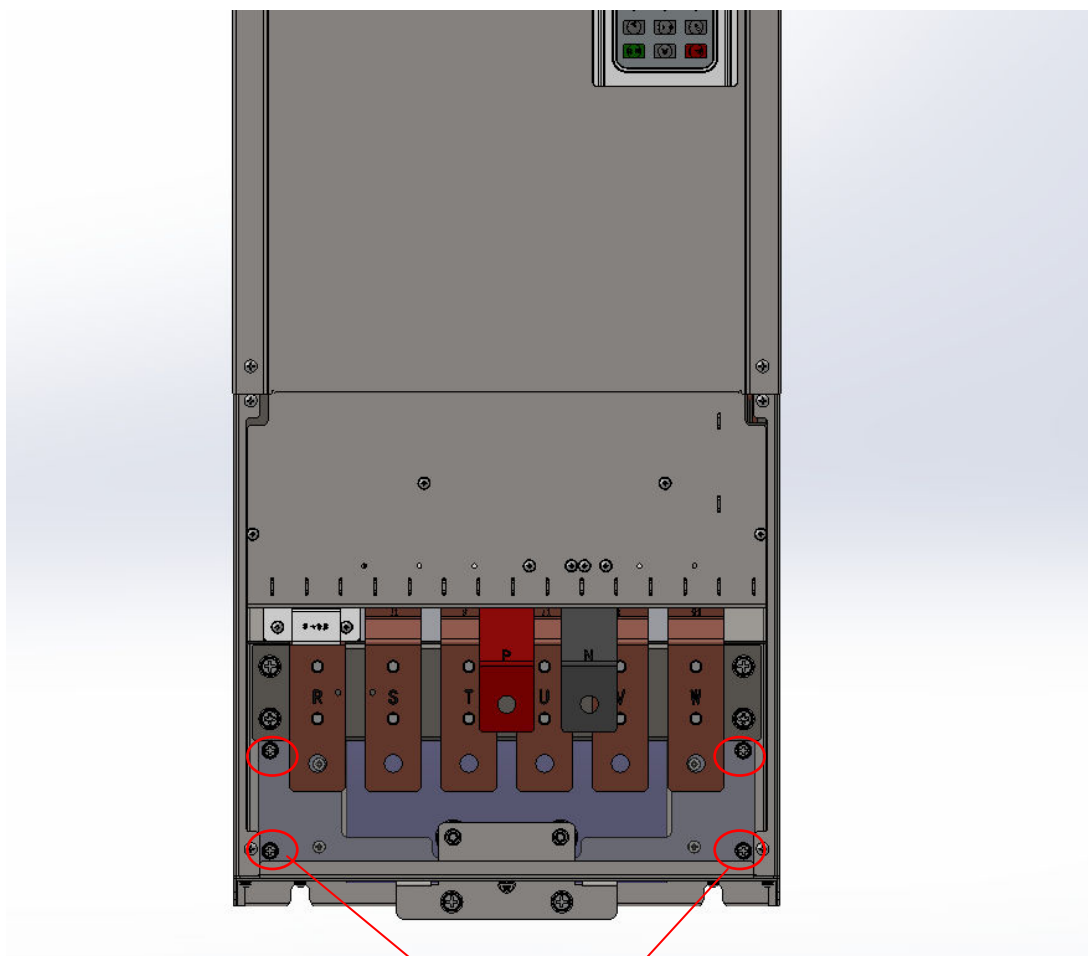

拆掉风机组件安装的 4 个 M6 螺栓

四、注意风机组件后部两个卡扣，将组件向上部提起，将风机组件从卡槽中拔出，此时风机组件完全可以从箱体中滑出。

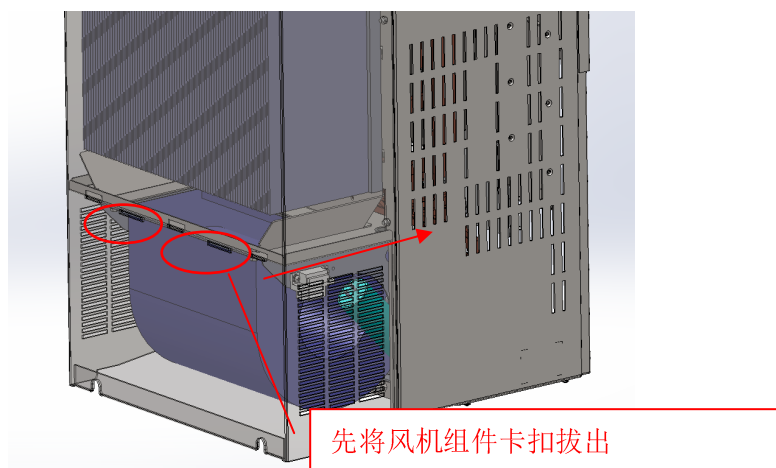

五、拉出风机组件，换装风机

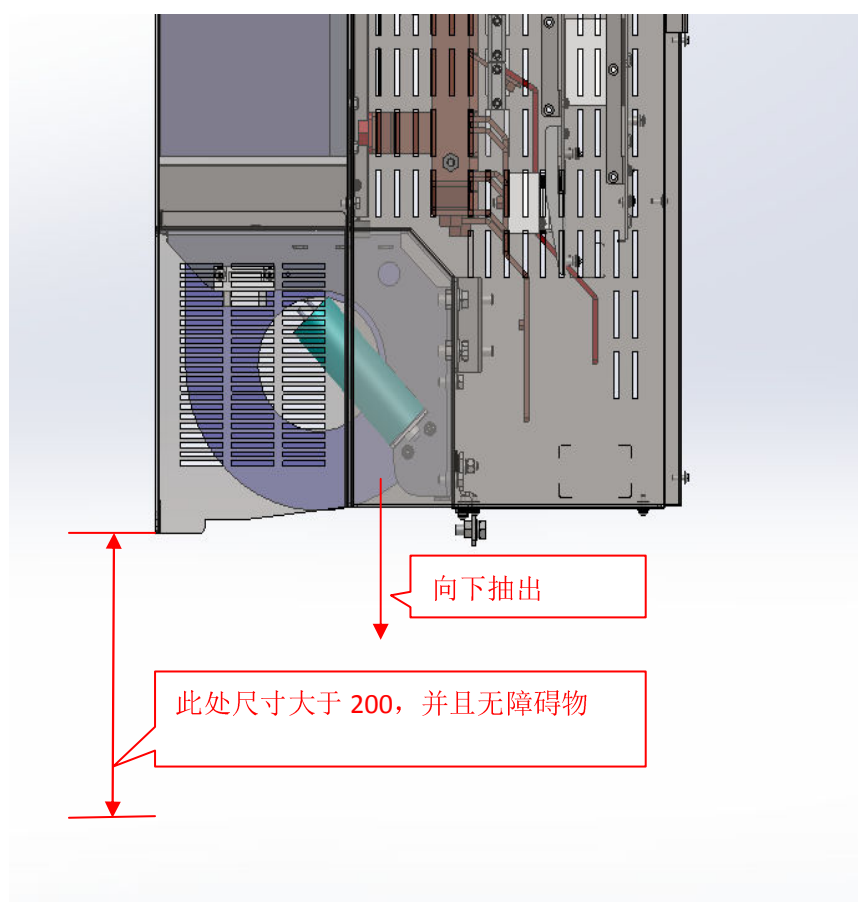

HF300 355~450KW 变频器&逆变器风机拆装维护指导书

一、松开四处 M6 螺钉，移开盖板

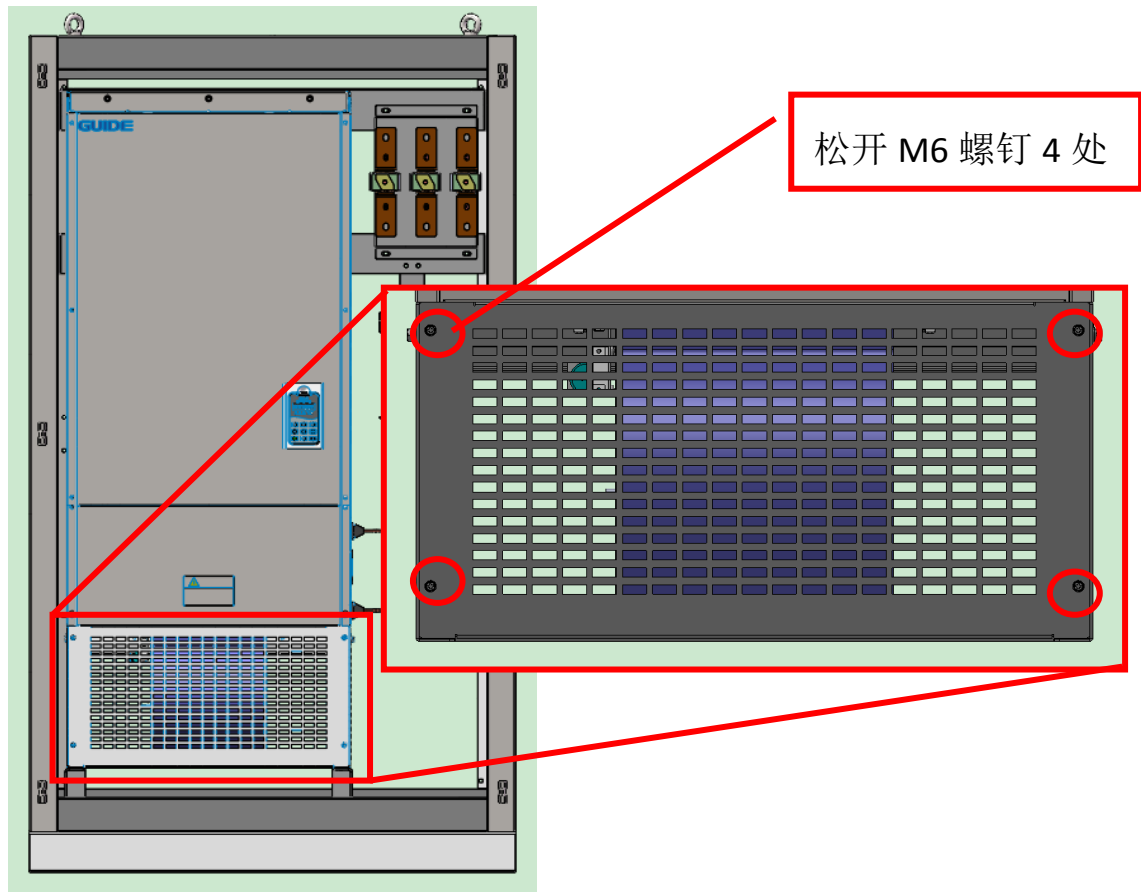

二、拔掉四位插头，松开两处 M6 螺钉

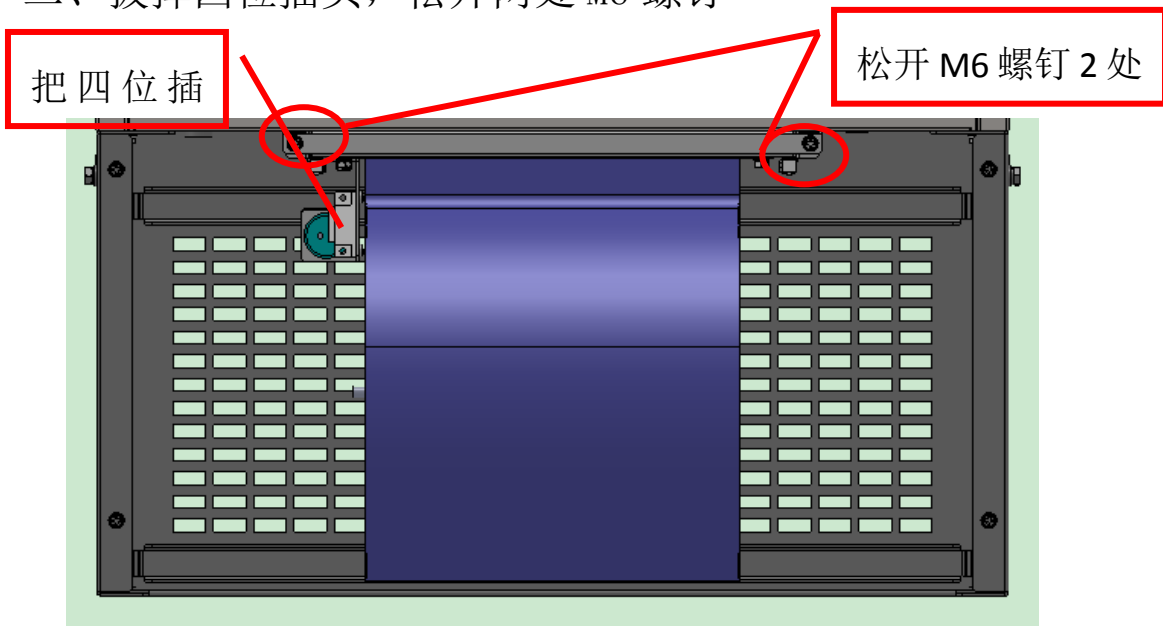

三、顺着变频器正前面沿滑道拉出风机组件

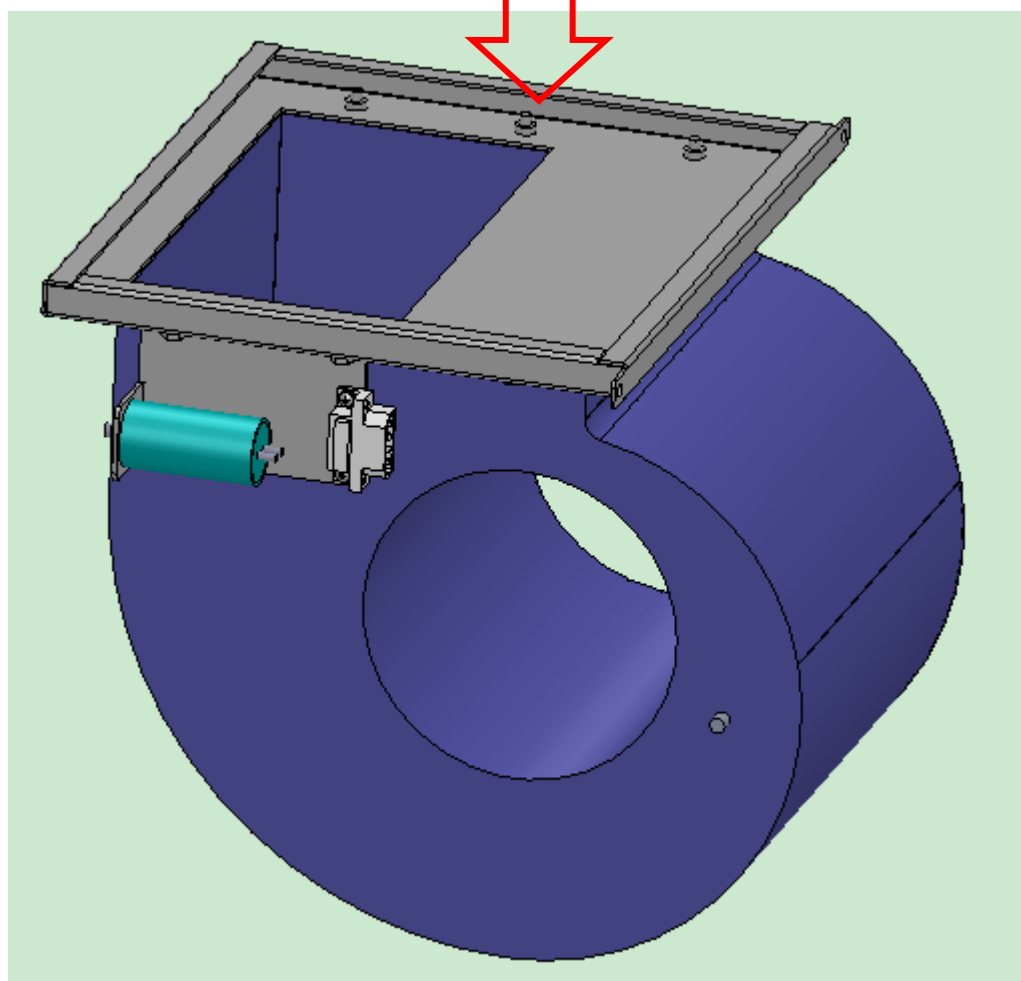
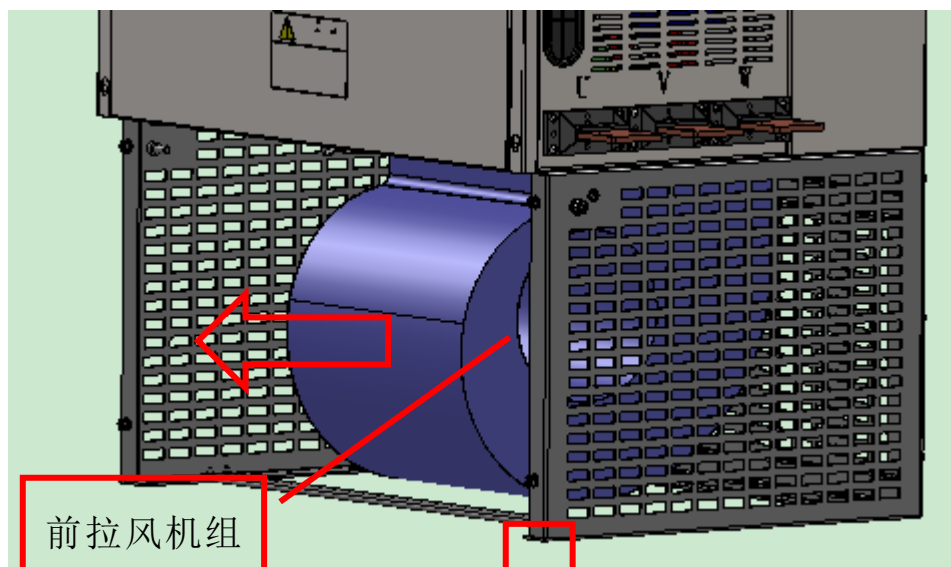

四、松开电线接线点和风机固定螺钉更换风机

